

Ready for
a next
level life?

SINGLE **1**
residences



Descripción

SINGLE1
residences



SE PARTE DE UNA EXPERIENCIA **SINGLE 1 RESIDENCES**

A tan solo 10 min del aeropuerto internacional Punta Cana, dentro del municipio de Verón en una zona de crecimiento urbano de mayor plusvalía de Punta Cana, se desarrolla **Single 1 Residences**, con **96** condos diseñados inteligentemente que priman espacios diáfanos con espectaculares estancias y las más altas calidades en mobiliario.

¿Por qué Invertir Single Residences?



Localización
Estratégica

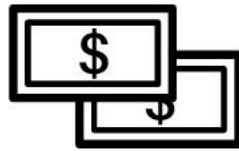

Conversión
del Dolar



Potencial
de Inversión

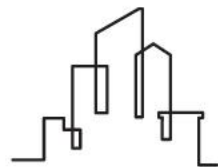

Infraestructura
de primer nivel



Promoción de Inversión
Extranjera directa



Roadmap del Proyecto

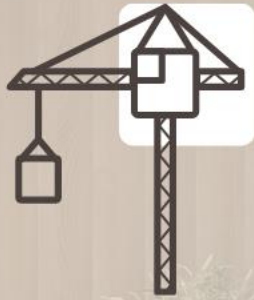

2021



INICIO DE OBRAS



2022



ENTREGA

Ubicación

SINGLE1
residences



Miami, Florida

Bahamas

Cancún México

La Habana, Cuba

Jamaica

Punta Cana, República Dominicana

San Juan, Puerto Rico

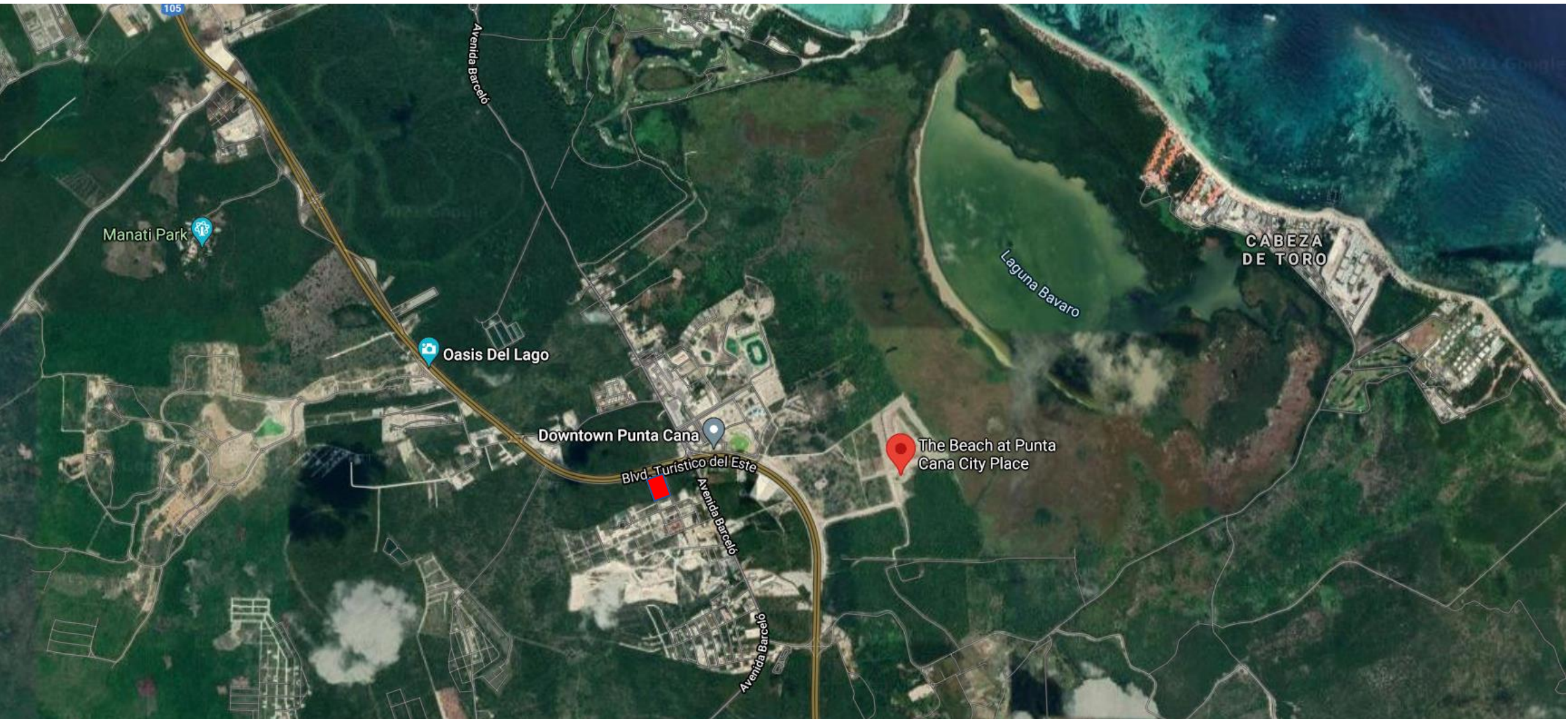

105

Manati Park

Oasis Del Lago

Downtown Punta Cana

Blvd. Turistico del Este

Avenida Barcelo

Avenida Barcelo

Laguna Bavaro

CABEZA DE TORO

The Beach at Punta Cana City Place

El proyecto Single 1 se encuentra situado próximo al cruce de la Av. Barceló con la autovía Boulevard Turístico del Este, con acceso directo desde El Boulevard Turístico del Este.



SINGLE1
residences



Iglesia Catolica

Yosai CrossFit

Dolphin Discovery Punta Cana



Downtown Punta Cana
Comida para llevar



LICORMART
Cash and Carry



SINGLE 1
residences

Bvd. Turístico del Este

Carretera Higüey - Miches

Avenida Barceló

105



Neighborhood

CONVENIENCE

Two minutes away you will find Downtown Mall or Ten minutes away to BlueMall Punta Cana...more than 50 fifty different restaurants, shops, events and entertainment every day.



BlueMall
PUNTA CANA



Isabella
STEAK & BISTRO



Single One is smack dab in the middle of a pulsing creative core.



FOOD & DRINK

Take your pick of great restaurants or Nightlife in the Bávaro area is part and parcel of the beach life. Sun and sea by day, party by night. The options are numerous: an underground cave-turned-disco, a unique Coco Bongo Vegas-style show and nightclub, or a quiet wine bar.

LIVE-CENTRIC, EAT-CENTRIC, WALK-CENTRIC AND BE YOU.



2 MINUTES
DOWNTOWN MALL



5 MINUTES
WHITE SAND BEACH



8 MINUTES
BLUE MALL



10 MINUTES
PUNTA CANA AIRPORT



Amenidades

SINGLE1
residences

Estos espacios que integran el proyecto se disponen de manera funcional para su uso cotidiano, sin perder la estética de las fachadas modernas que crean juegos de formas tradicionales. El objetivo del proyecto es crear una sensación de amplitud e integración que permita la comunicación de los espacios sociales, los cuales representan el eje principal del proyecto, integrando incluso los espacios privados, como por ejemplo la terraza que conecta las habitaciones del segundo nivel.

La simbiosis entre lo moderno y lo tropical permite que el proyecto cumpla con una estética acertada, caracterizada por materiales nobles, colores cálidos y espacios bien iluminados y ventilados (naturalmente). Se hace uso de los jardines incluidos en las fachadas, para ayudar a armonizar y acentuar lo tropical en las fachadas.

General del Proyecto:

- Acceso Principal Vehicular.
- Garita de Seguridad.
- Parqueos exteriores.
- Motor lobby.
- Pasillos de circulación entre edificios.
- Piscina (**semi-olímpica 25m x 9m x 1.40m de profundidad**)
- Restaurant (Desayunos área Terraza Lobby)
- Cocina y servicios.
- Lobby/Recepción/ Elevador.
- Baño cortesía.
- Núcleos de circulación vertical.
- Gimnasio.
- Salón Coworking.
- Circuito peatonal.
- Cancha Multiusos (Tennis, Basquetbol, Futbol)
- Sección de Yoga.
- Área de jardín para mascotas.
- Planta eléctrica.

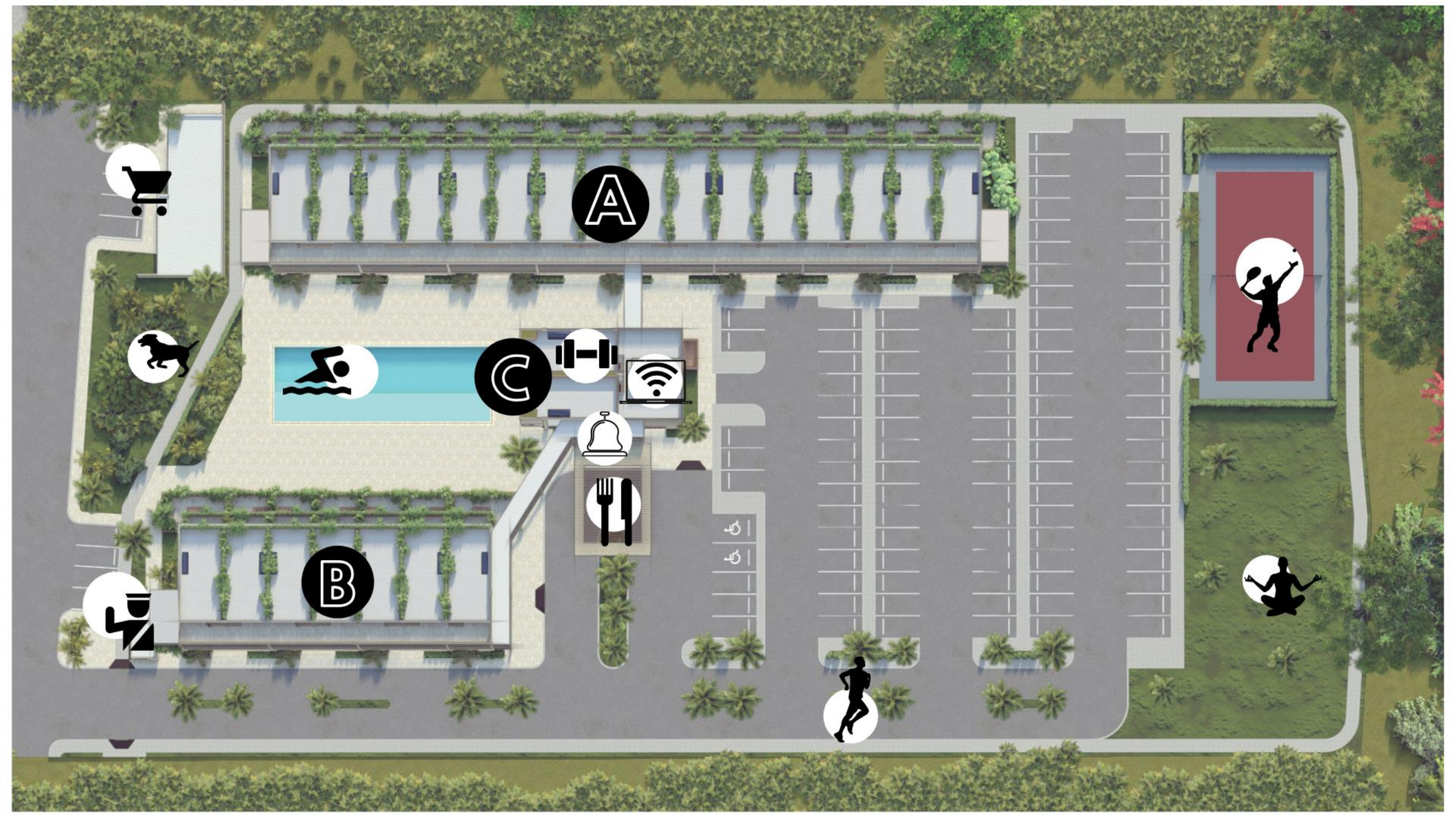

A

B

C





Single I Residences cuenta con amenidades diseñadas especialmente para valorar los tiempos de calidad fuera de la rutina diaria, enfocándose en espacios inteligentes, prácticos y modernos, tal y como el área de **Coworking**, ideal para potencializar tus ideas o simplemente distraer tu mente, un **GYM equipado** para mantenerte siempre en forma, un **jardín Zen** de meditación o hacer Yoga, una sección con **áreas verdes**, donde se tendrá un espacio **Dog Park** para que las mascotas disfruten libremente con otras mascotas, una **piscina** de tamaño ideal para nadar o relajarse, un **Multi-Sport Court**, para aquellas personas que aman el deporte de alto impacto como Basquetbol, Tenis o Fútbol rápido, cuenta también con un **circuito de Jogging** para los que no pueden dejar de correr y comenzar su día ó para los que terminan su día, también se tendrá un área de **lavandería**, un practico **mini-market 24/7** disponible para todo propietario o inquilino, contará con una sección de **Bodega-almacén** (preguntar por este servicio), membresía en el **club de Playa**, membresía para propietarios amantes del **Golf** (Cocotal Club de Golf), y por condomino incluye **1 estacionamiento** y sobre todo la seguridad privada que controla los accesos y salidas a **Single I Residences**, creando una ambiente de tranquilidad y seguridad a todos los propietarios.





5km



© 2021 Google

© 2021 Google

Memoria de Calidades

SINGLE1
residences

MOBILIARIO, ACCESORIOS Y EQUIPAMIENTO

- Sofá 3 plazas, con telas a elegir
- Mesa de Centro Cuadrada
- Decoración General
- Mobiliario Exterior
- Colchón King
- Taburetes desayunador
- Iluminación General
- Closet
- Closet privado
- Tv Smart de 55"
- Washer/Dryer (a gas)
- Estufa de tope (a gas)
- Horno
- Refrigerador
- En Baño: Lavamanos Monolítico flotante con repisa en madera preciosa
- Baño revestido en porcelánico español de 0.60m x 1.20m (cuenta con aparatos sanitarios de alta calidad), 1 espejo retro iluminado, y como diseño especial en la parte de ducha tendrá una increíble caja de luz **RETROILUMINADA** de piso a techo con una infografía temática a escoger por el propietario (20 diseños).
- Los pisos en todas las áreas serán de porcelánico español imitación madera (Rovere Tabacco de Azuvi)
- El espacio de dormitorio esta elevado sobre una plataforma que sirve a su vez como almacenamiento (GAVETAS).
- Los espacios de dormitorio y sala, se delimitan con Louvers de Moso Bamboo (elegantes persianas)
- Se cuenta con falso techo decorativo en la zona de dormitorio, vestíbulo y baño.
- Cuenta con aire central individual.
- 1 Abanico de techo en dormitorio.
- Lavadora y secadora (a gas) en closet de aseo.
- Los muros y puertas de vestíbulo, van revestidos a juego en madera preciosa.

Planos

SINGLE1
residences

Superficie total construida: **9,450.14 M2**

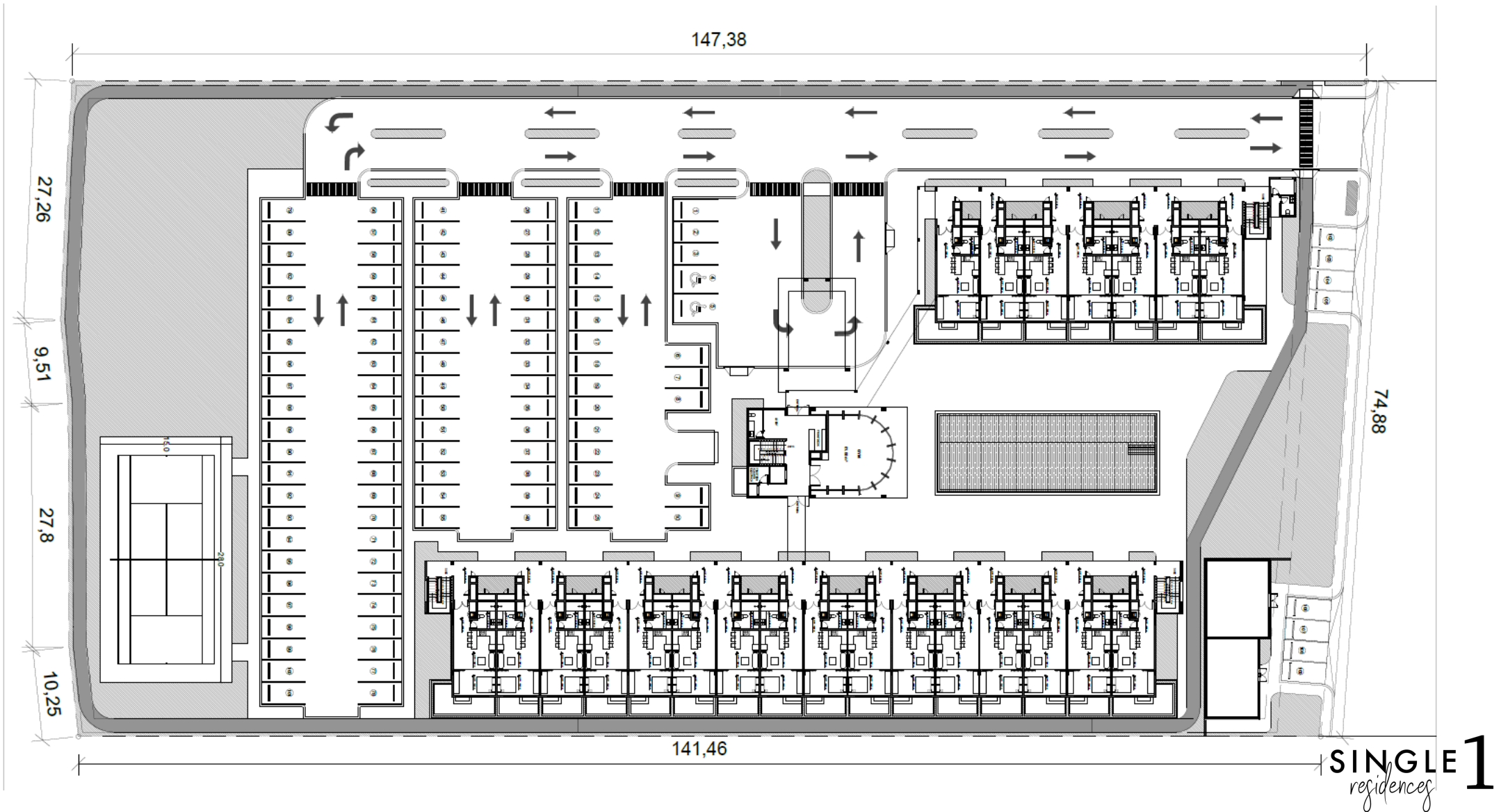

Superfície total Áreas Verdes: **1,593 m**

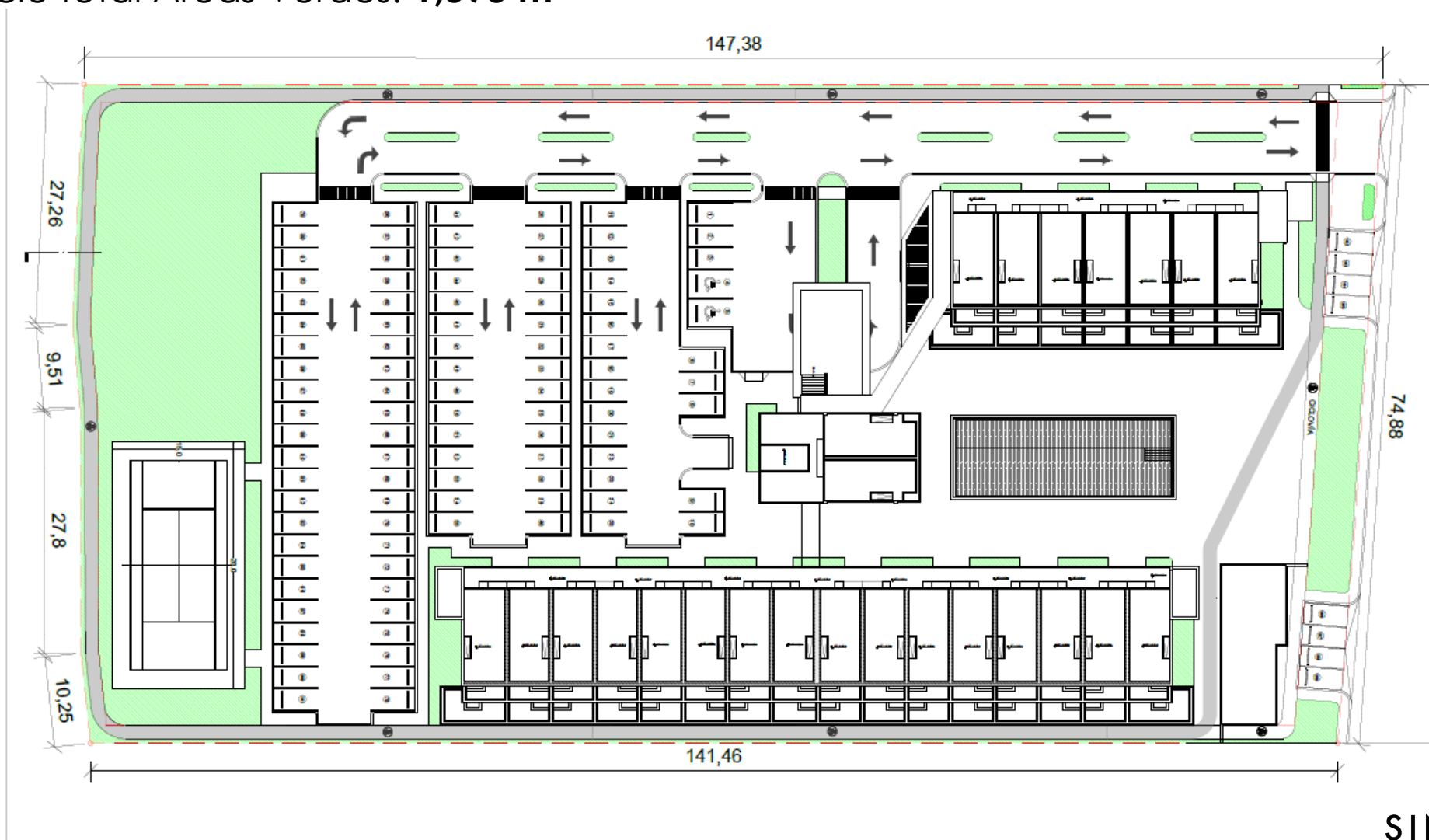

Parqueos: El proyecto en general cuenta con 109 parqueos, 96 para propietarios (1 x unidad) + 3 parqueos en el Lobby para visitas o espera + 2 parqueos para discapacitados + 8 parqueos en la parte frontal o exterior al proyecto (área comercial)

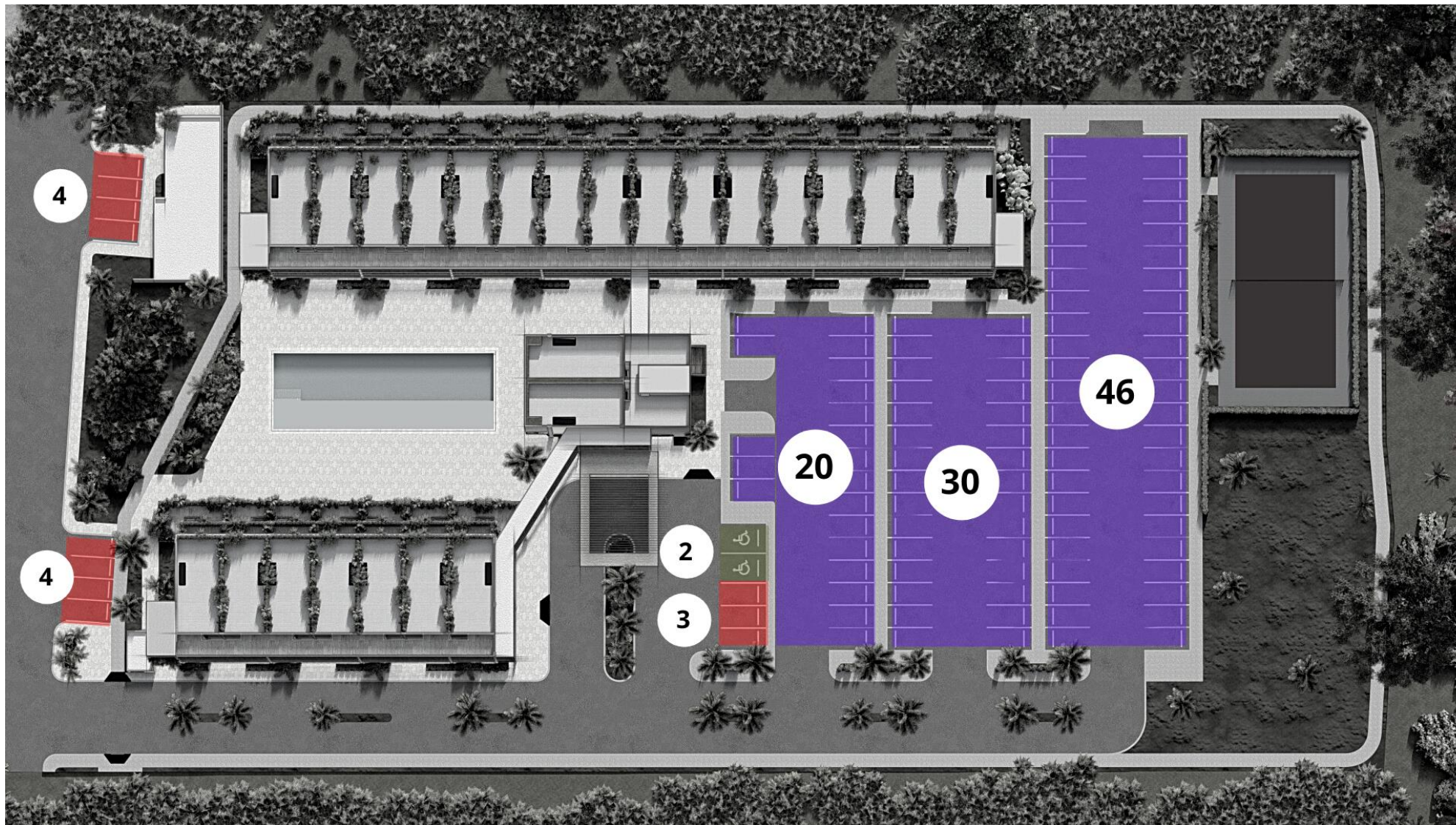

Planta Arquitectónica

EDIF. A

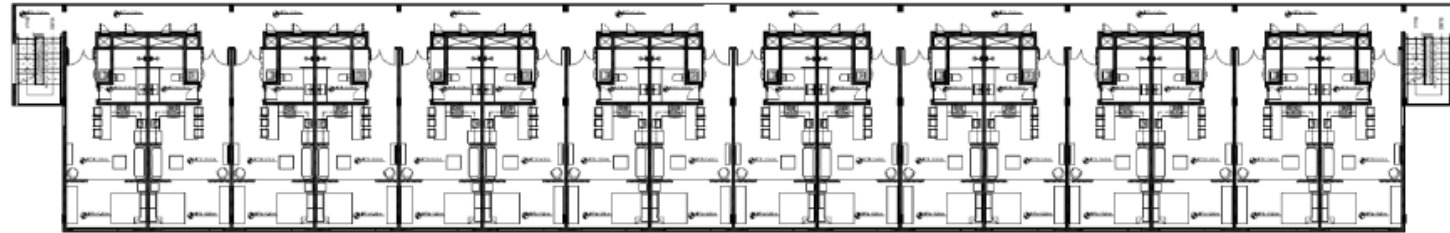
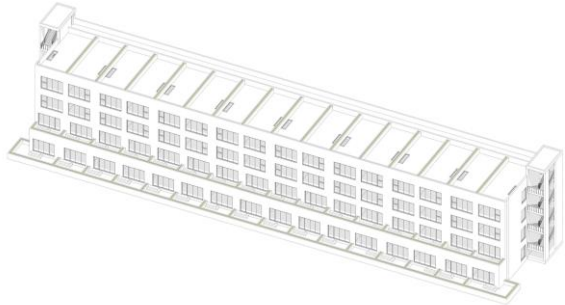

El tercer nivel del Edif. A está compuesto por 16 apartamentos de 55.34 m². Además, dos núcleos de escaleras de emergencias a los extremos del edificio.

Edif. B

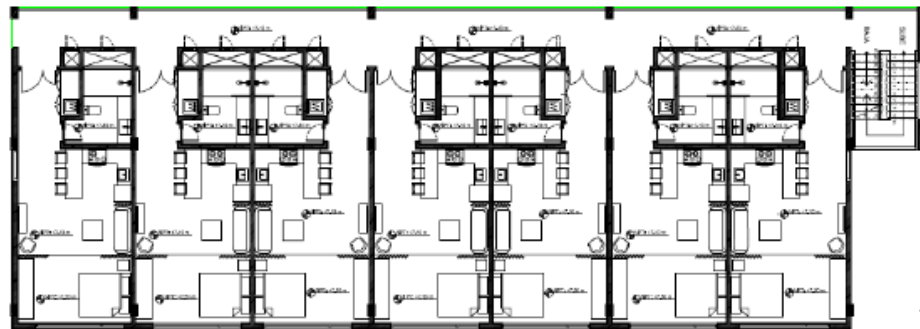
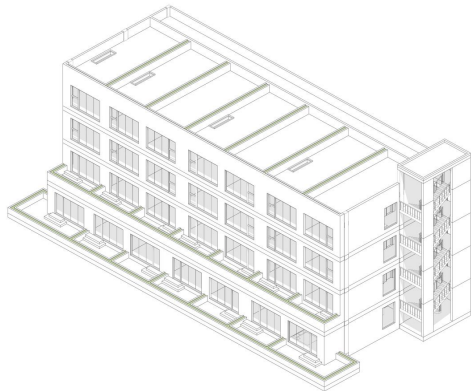

El tercer nivel del Edif. B está compuesto por 7 apartamentos de 55.34 m². Además, dos núcleos de escaleras de emergencias a los extremos del edificio.



TORRE C

Coworking Room (2do Nivel)



GYM (1er Nivel)

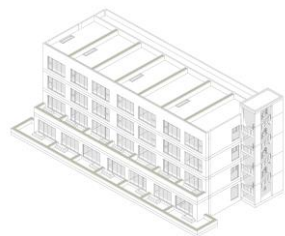

Hacia Torre B

Terraza Healthy Bar (2do Nivel)

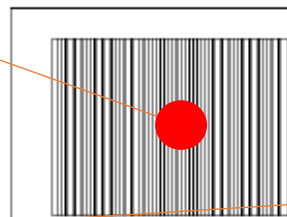

Lobby

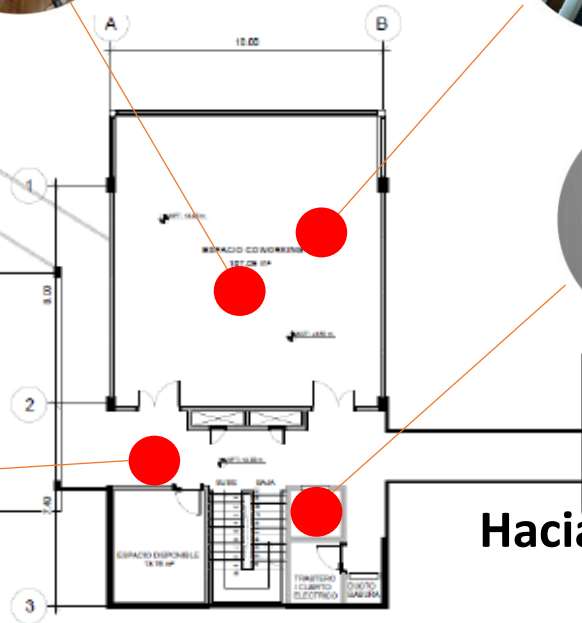

Ascensor

Hacia Torre A

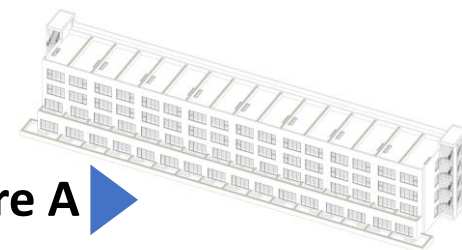

El segundo nivel del Edif. C se encuentra un salón Business Center, un núcleo de escaleras y ascensor, y un cuarto de servicio.



TORRE C

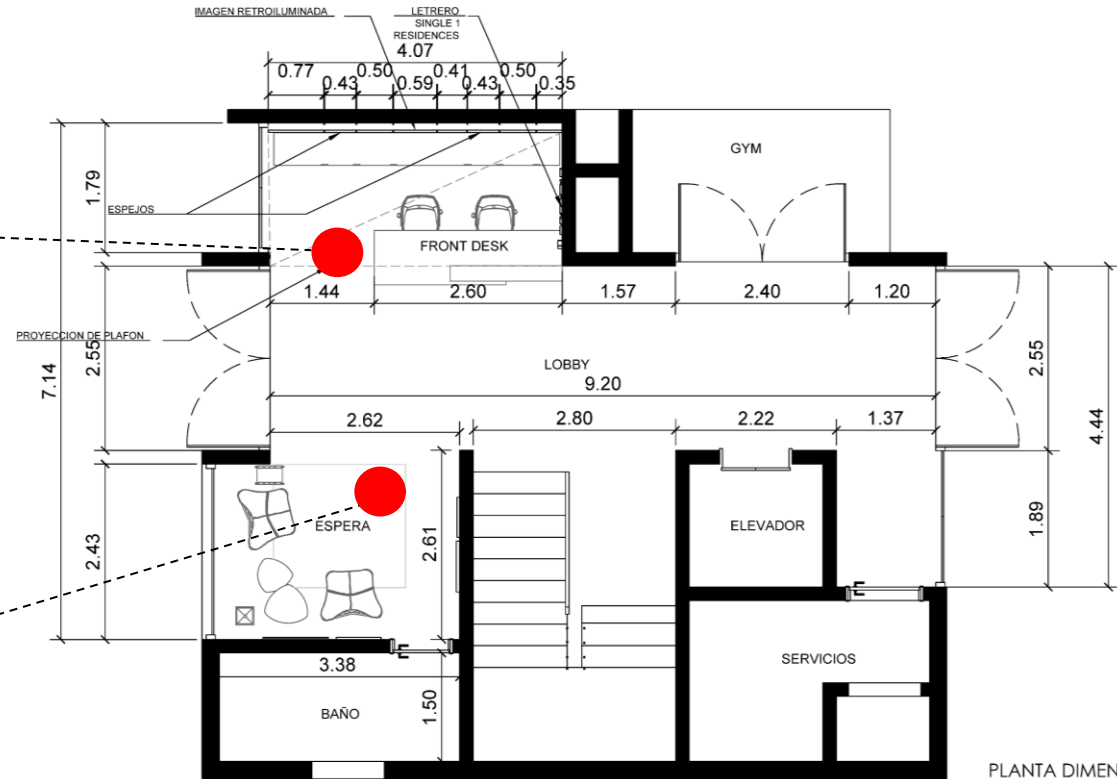

PLANTA DIMENSIONADA LOBBY



Metraje estimado por apartamento tipo: **55.34 m2 Unidades** tipo estudio, con cocina/comedor, sala de estar, área de cama y baño privado. Total unidades en el proyecto: 96 unidades



1. Laundry Closet
2. Bathroom
3. Kitchen & Dining
4. Living room
5. Bedroom
6. Clothes Closet

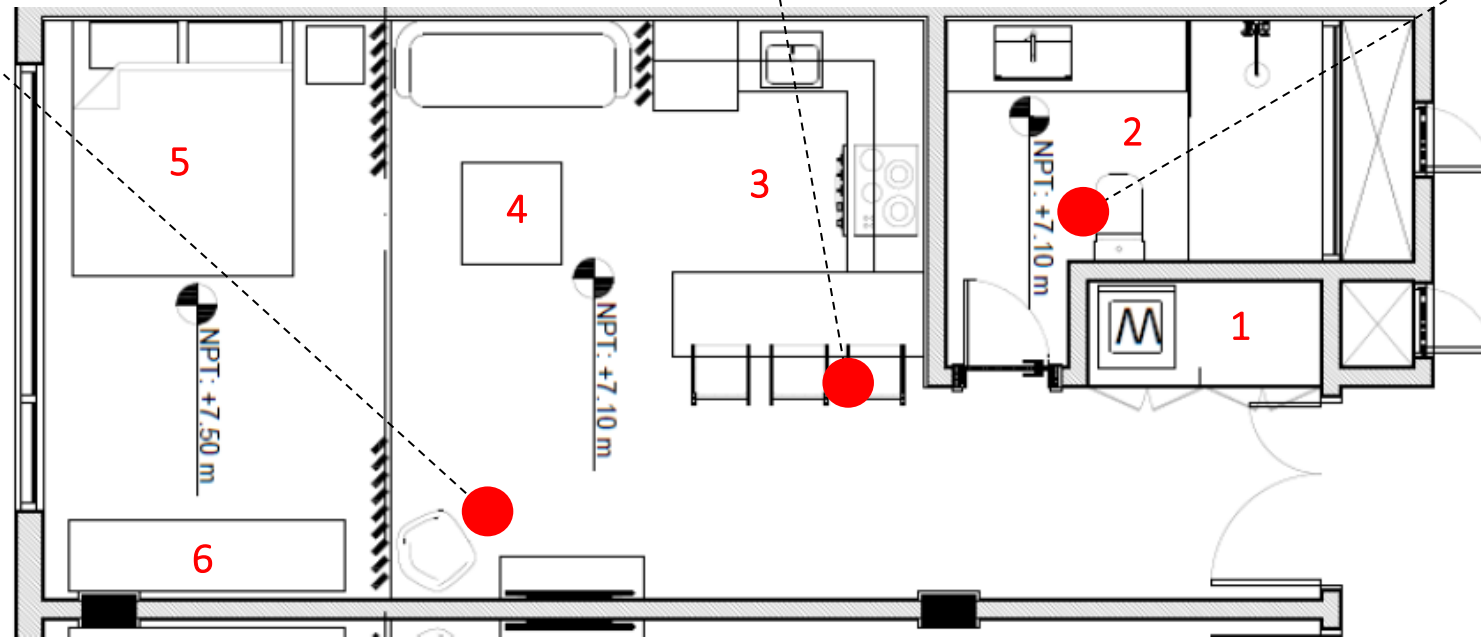



Planta Dimensionada 3er Nivel

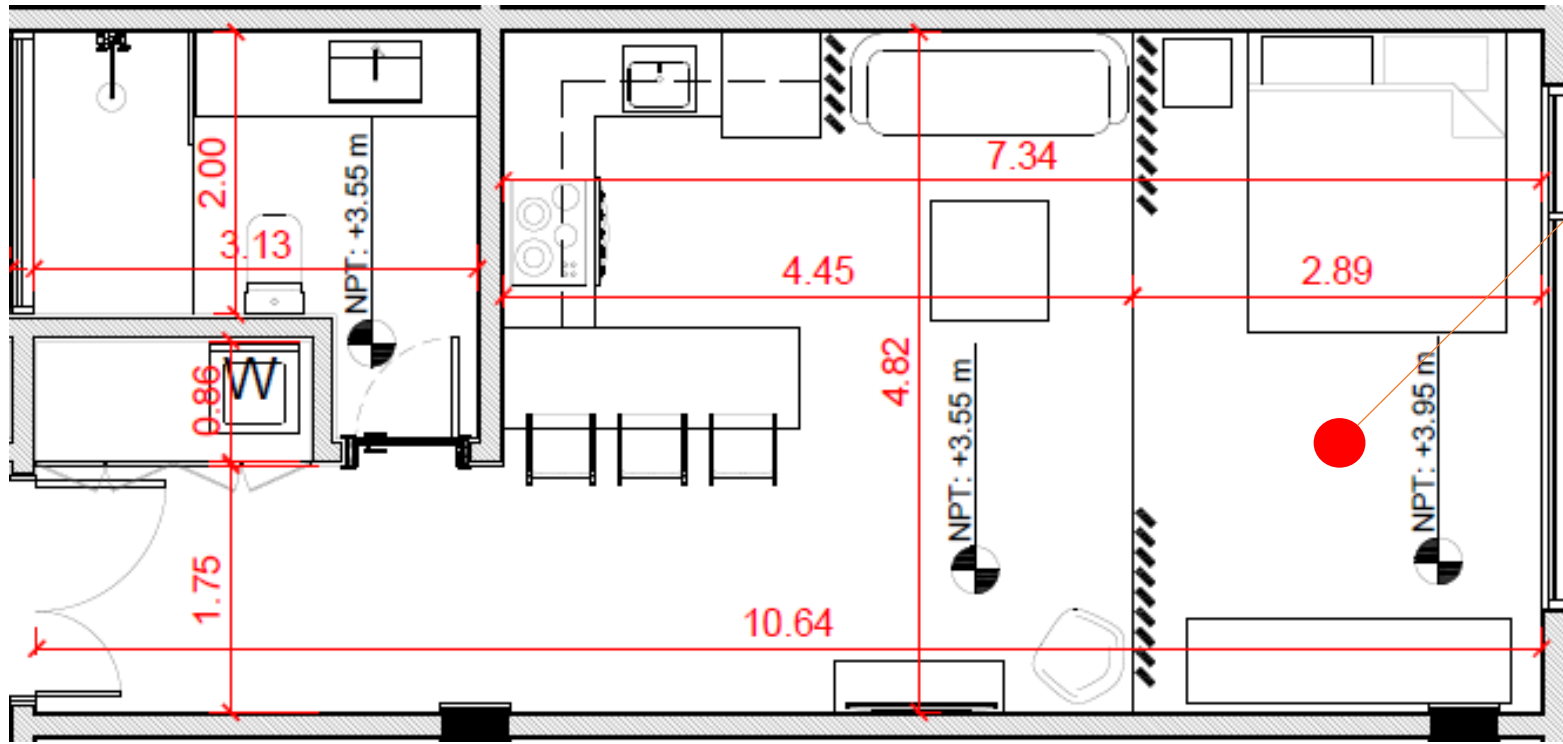



Planta Dimensionada
4to Nivel



Planta Dimensionada
4to Nivel **“ROOFTOP”**

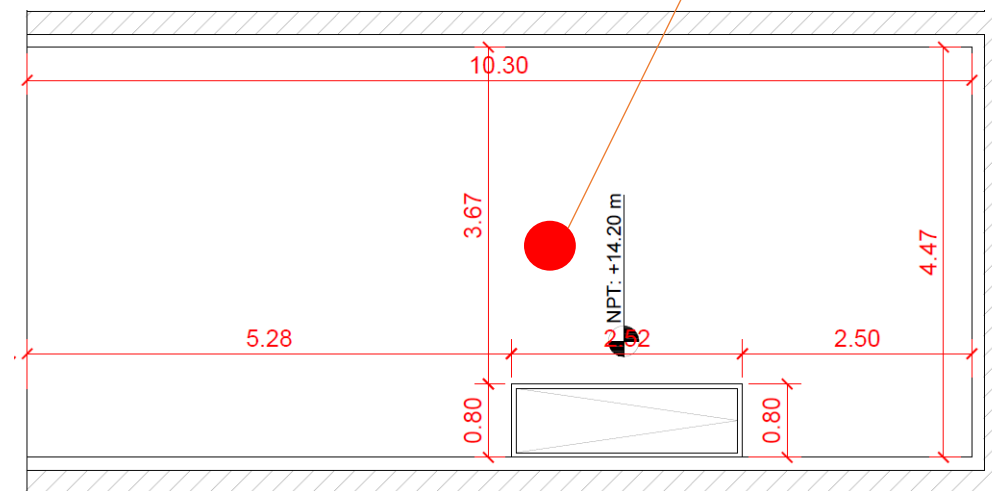
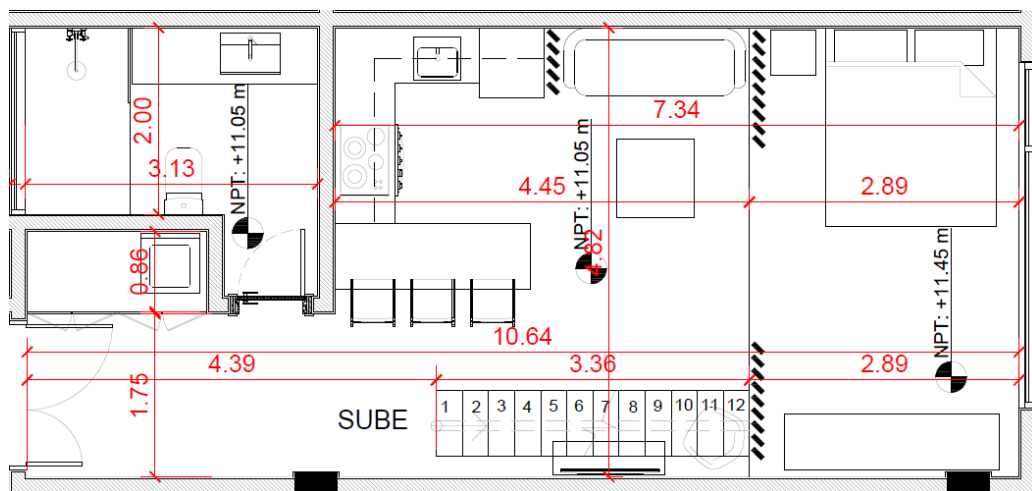

Renders

SINGLE1
residences







SINGLE 1
Residences









SINGLE
Residence



A-101





A

C

B

A-201





A-301





A

C

B

A-401

A-401



IDEAS
ROOFTOP
SINGLE 1
residences

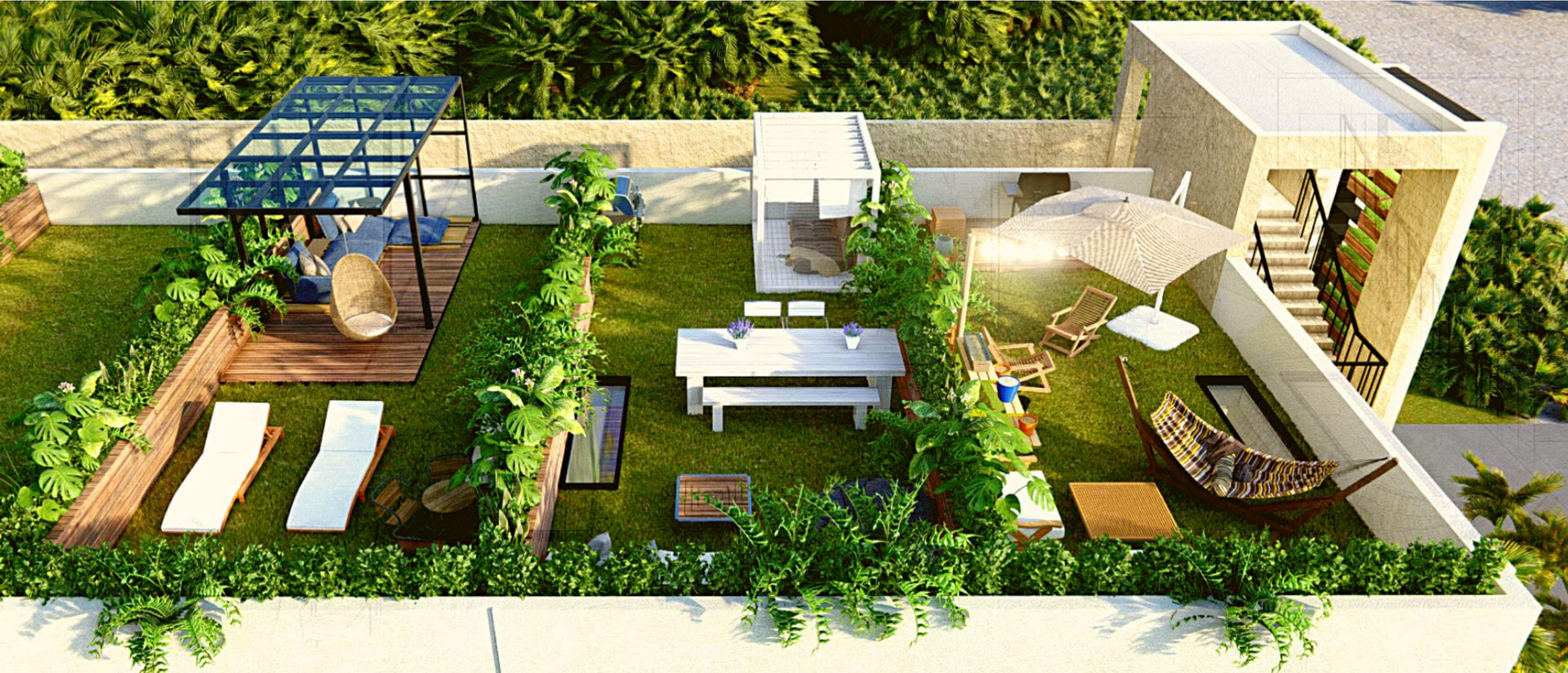

Detalle de Unidades por Torre

Torre
A

Torre
C

Torre
B





-  TORRE A
-  TORRE B
-  TORRE C
-  Locales Comerciales

Lobby



Healthy Bar



Coworking Room



GYM



SINGLE₁
residences

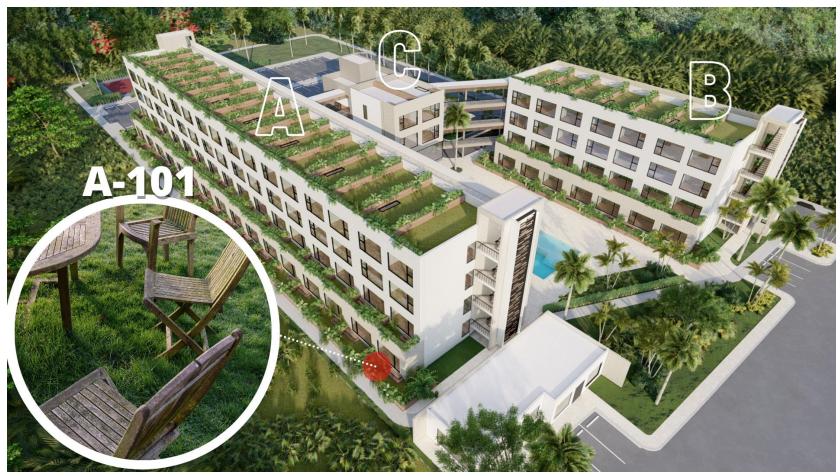

TORRE A PISO 1

PISO	TORRE A	m2	m2 extra	PRECIO
1	A-101	56.34	24	122,123
	A-102	55.34	12	111,401
	A-103	55.34	12	111,401
	A-104	55.34	12	111,401
	A-105	55.34	12	111,401
	A-106	55.34	12	111,401
	A-107	55.34	12	111,401
	A-108	55.34	12	111,401
	A-109	55.34	12	111,401
	A-110	55.34	12	111,401
	A-111	55.34	12	111,401
	A-112	55.34	12	111,401
	A-113	55.34	12	111,401
	A-114	55.34	12	111,401
	A-115	55.34	12	111,401
	A-116	56.34	24	122,123

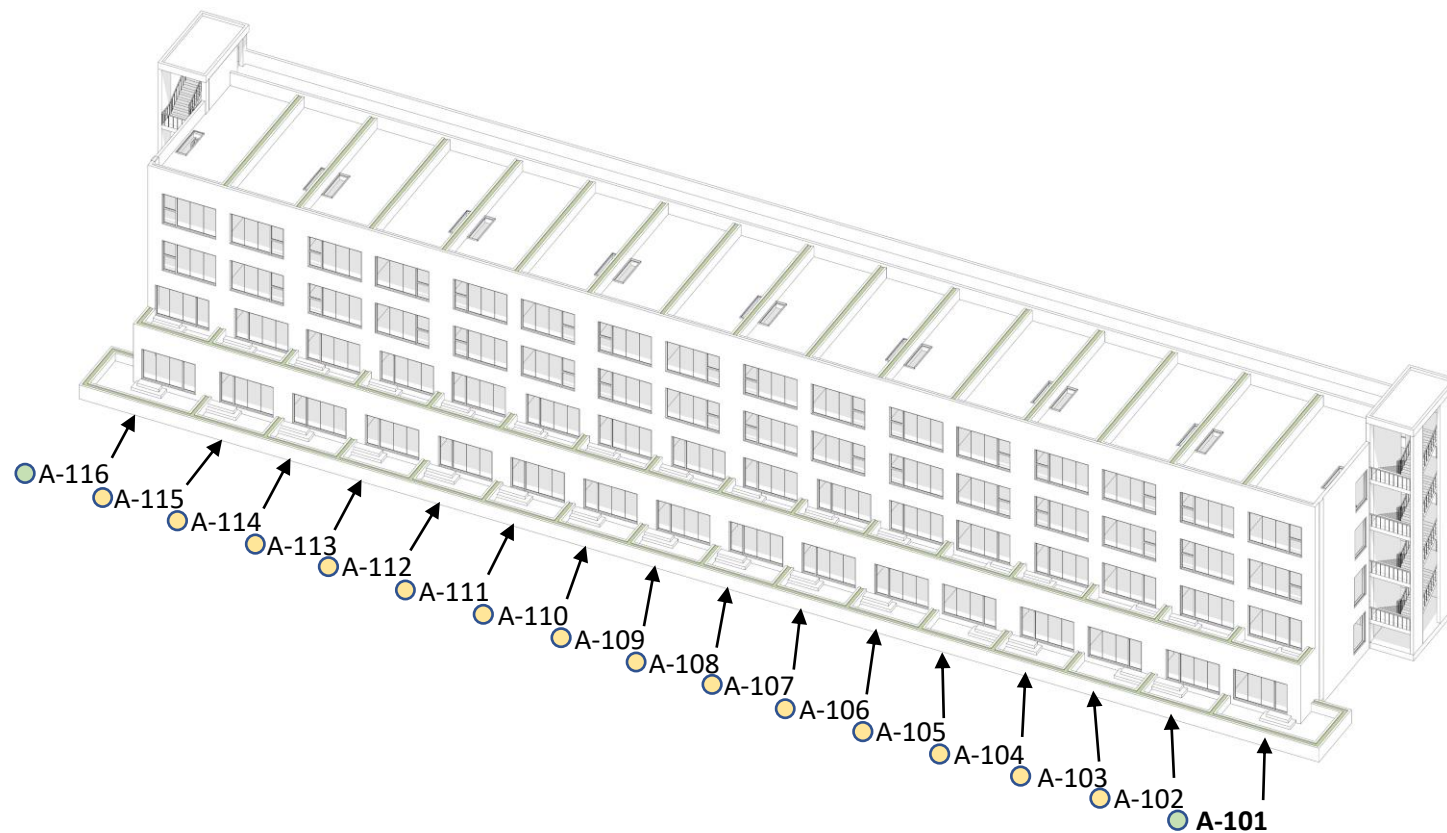

SINGLE 1
residences



TORRE A PISO 2

PISO	TORRE A	m2	m2 extra	PRECIO
2	A-201	56.34	10.08	116,137
	A-202	55.34	9.65	116,137
	A-203	55.34	9.65	116,137
	A-204	55.34	9.65	116,137
	A-205	55.34	9.65	116,137
	A-206	55.34	9.65	116,137
	A-207	55.34	9.65	116,137
	A-208	55.34	9.65	116,137
	A-209	55.34	9.65	116,137
	A-210	55.34	9.65	116,137
	A-211	55.34	9.65	116,137
	A-212	55.34	9.65	116,137
	A-213	55.34	9.65	116,137
	A-214	55.34	9.65	116,137
	A-215	55.34	9.65	116,137
	A-216	56.34	10.08	116,137

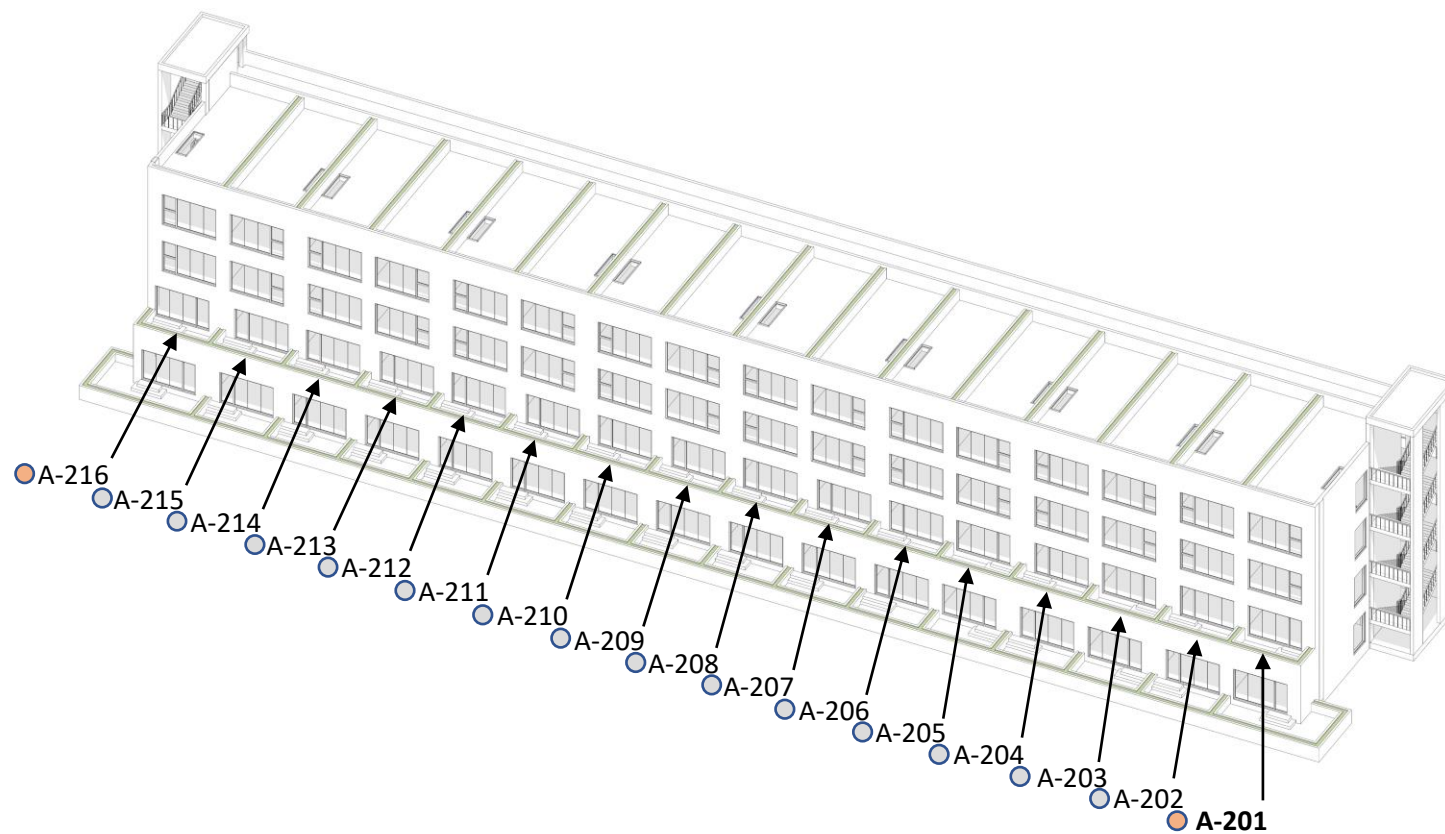

SINGLE 1
residences



TORRE A PISO 3

PISO	TORRE A	m2	m2 extra	PRECIO
3	A-301	56.34	0	98,900
	A-302	55.34	0	98,900
	A-303	55.34	0	98,900
	A-304	55.34	0	98,900
	A-305	55.34	0	98,900
	A-306	55.34	0	98,900
	A-307	55.34	0	98,900
	A-308	55.34	0	98,900
	A-309	55.34	0	98,900
	A-310	55.34	0	98,900
	A-311	55.34	0	98,900
	A-312	55.34	0	98,900
	A-313	55.34	0	98,900
	A-314	55.34	0	98,900
	A-315	55.34	0	98,900
	A-316	56.34	0	98,900

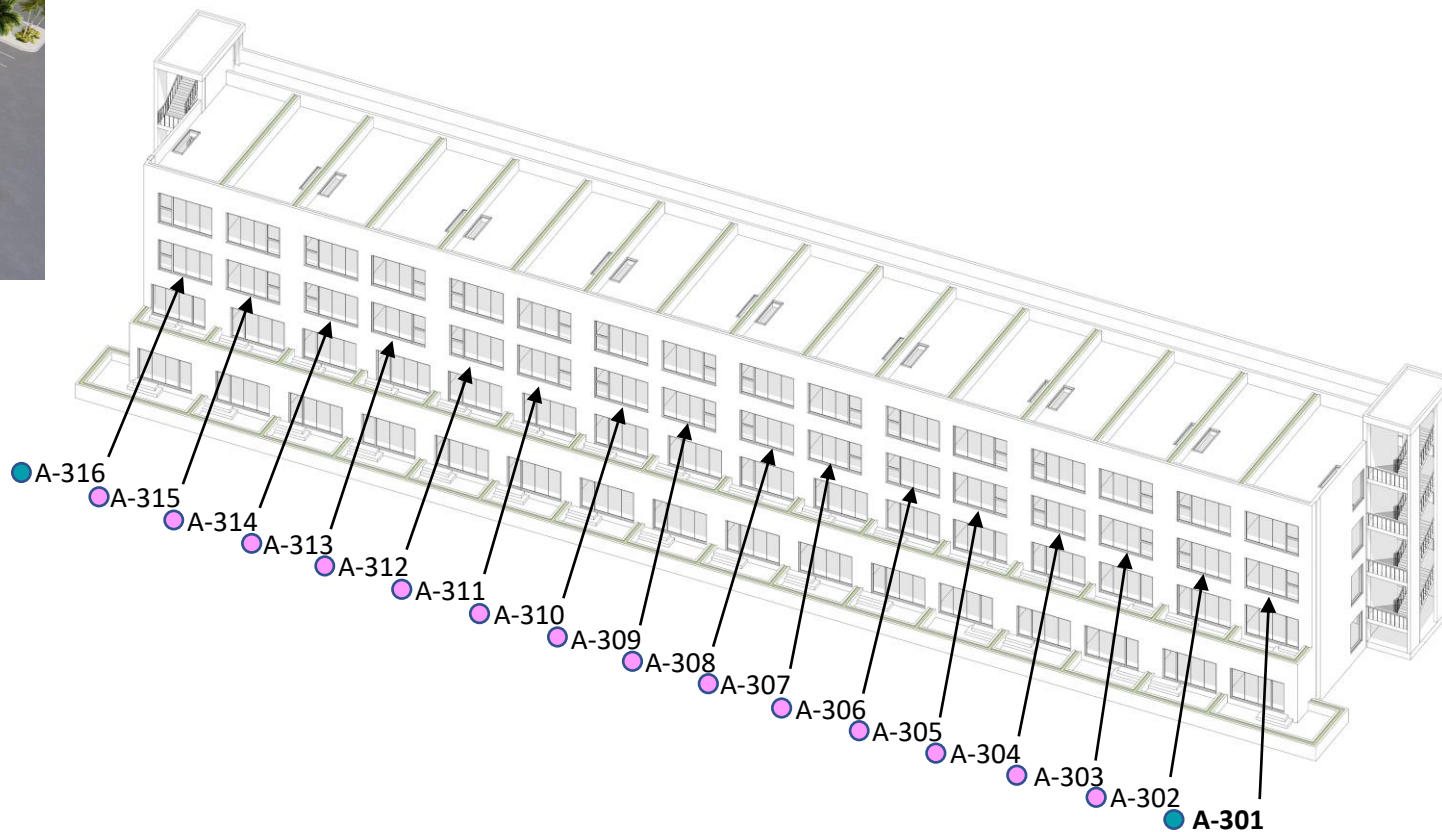

SINGLE 1
residences



TORRE A PISO 4

PISO	TORRE A	m2	m2 extra	PRECIO
4	A-401	56.34	56.34	129,900
	A-402	55.34	55.34	129,900
	A-403	55.34	55.34	129,900
	A-404	55.34	55.34	129,900
	A-405	55.34	55.34	129,900
	A-406	55.34	55.34	129,900
	A-407	55.34	55.34	129,900
	A-408	55.34	55.34	129,900
	A-409	55.34	55.34	129,900
	A-410	55.34	55.34	129,900
	A-411	55.34	55.34	129,900
	A-412	55.34	55.34	129,900
	A-413	55.34	55.34	129,900
	A-414	55.34	55.34	129,900
	A-415	55.34	55.34	129,900
	A-416	56.34	56.34	129,900

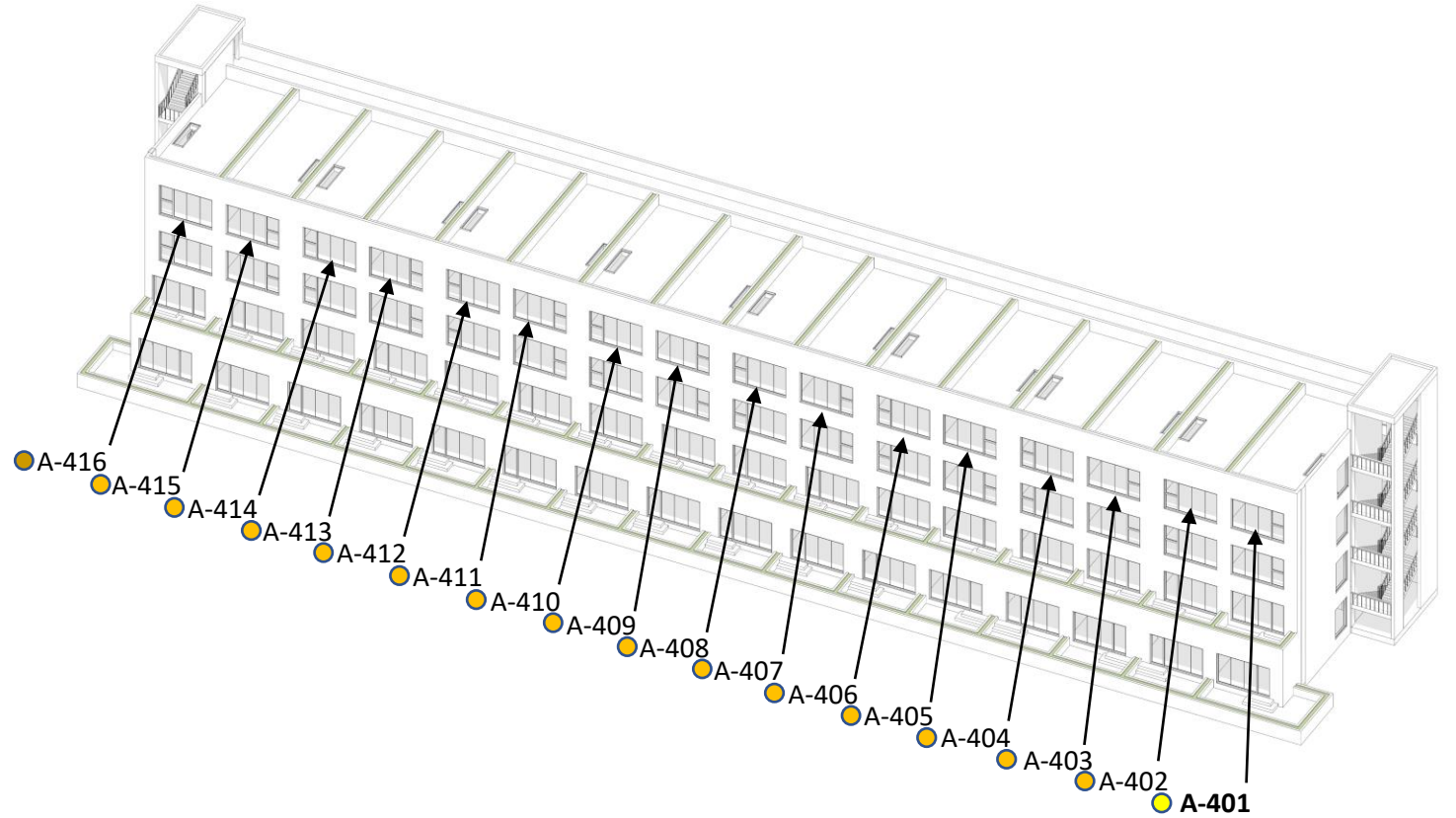

SINGLE 1
residences



TORRE **B** PISO **1**

PISO	TORRE B	m2	m2 extra	PRECIO
1	B-101	56.34	24	122,123
	B-102	55.34	12	111,401
	B-103	55.34	12	111,401
	B-104	55.34	12	111,401
	B-105	55.34	12	111,401
	B-106	55.34	12	111,401
	B-107	56.34	24	122,123

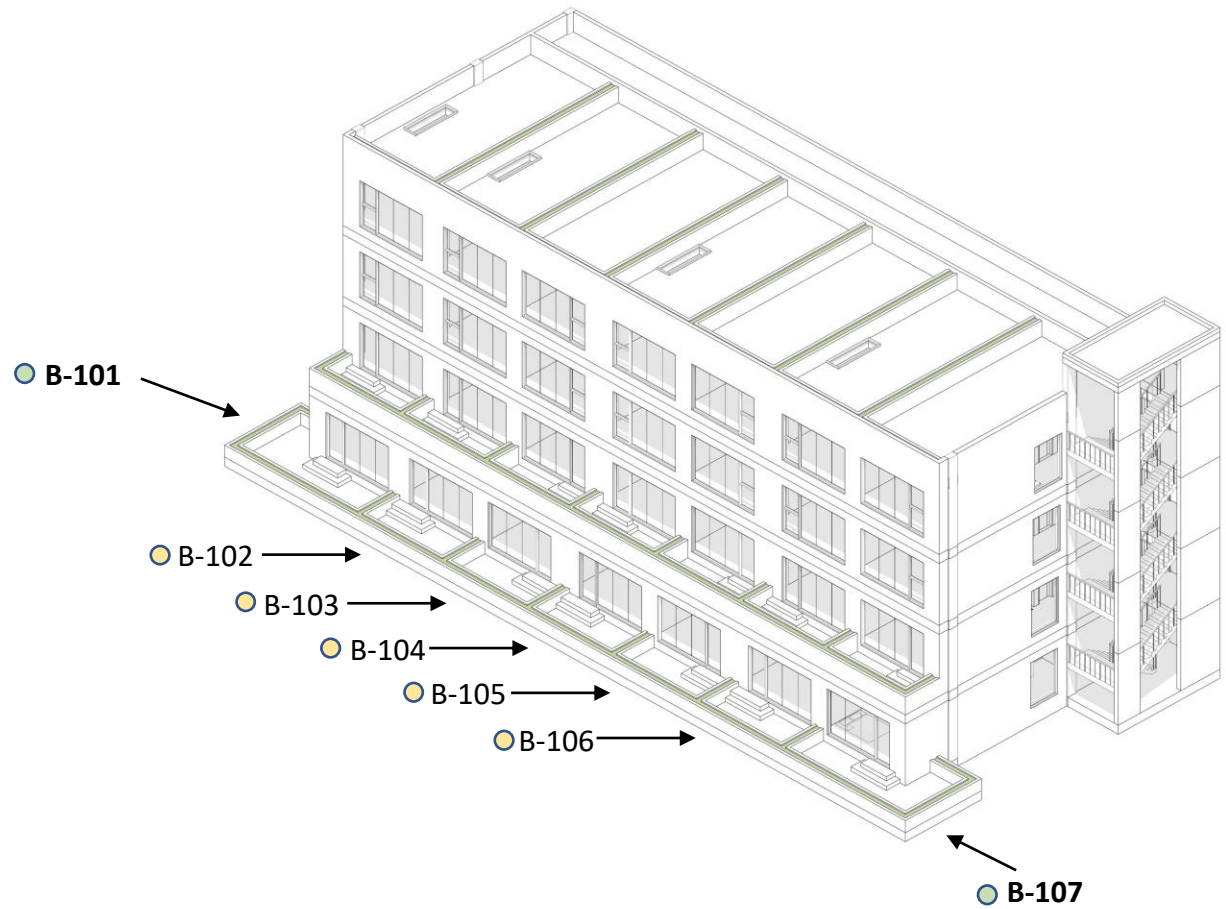

SINGLE1
residences



TORRE **B** PISO 2

PISO	TORRE B	m2	m2 extra	PRECIO
2	B-201	56.34	10.08	116,137
	B-202	55.34	9.65	116,137
	B-203	55.34	9.65	116,137
	B-204	55.34	9.65	116,137
	B-205	55.34	9.65	116,137
	B-206	55.34	9.65	116,137
	B-207	56.34	10.08	116,137

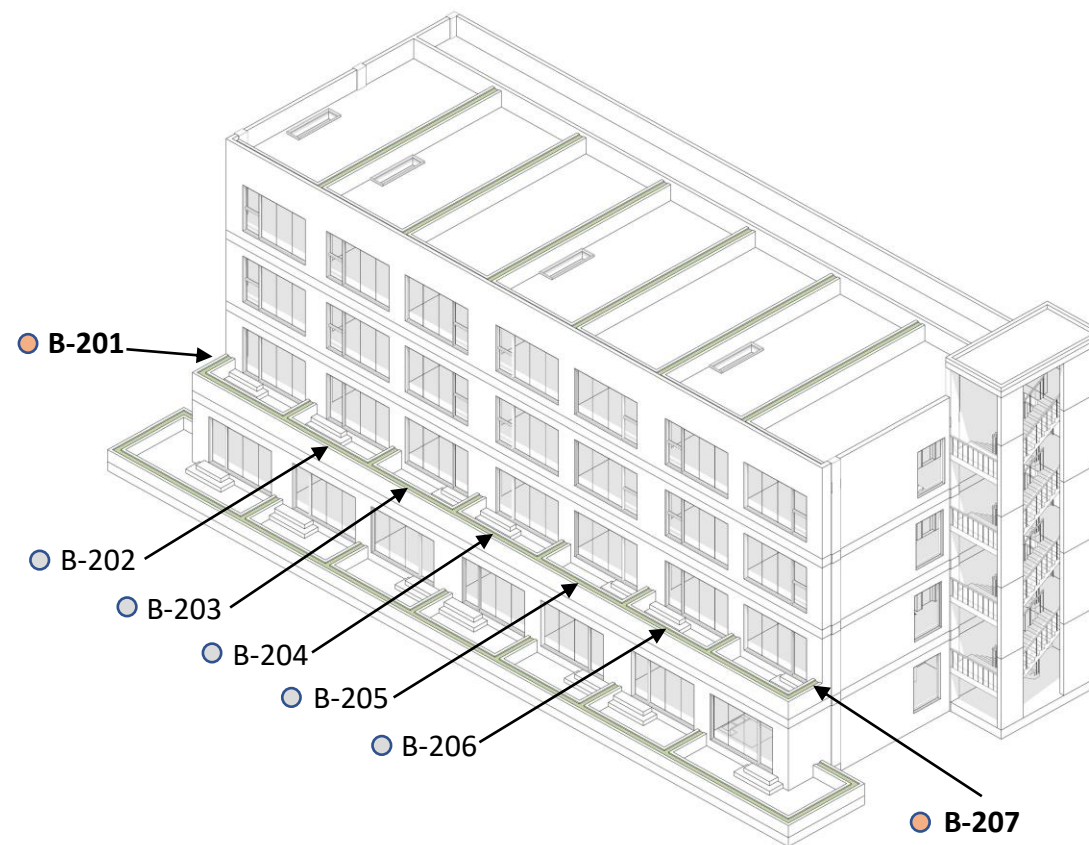

SINGLE **1**
residences



TORRE **B** PISO **3**

PISO	TORRE B	m2	m2 extra	PRECIO
3	B-301	56.34	0	98,900
	B-302	55.34	0	98,900
	B-303	55.34	0	98,900
	B-304	55.34	0	98,900
	B-305	55.34	0	98,900
	B-306	55.34	0	98,900
	B-307	56.34	0	98,900

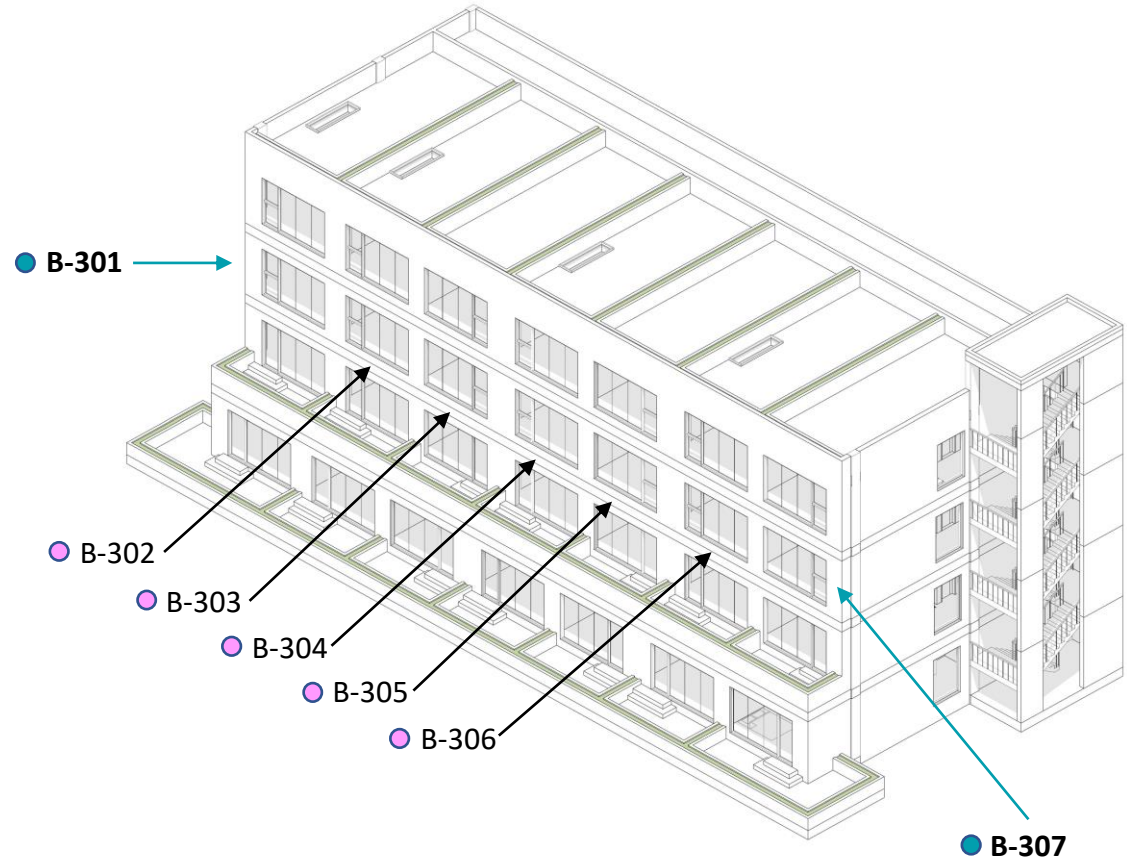

SINGLE1
residences

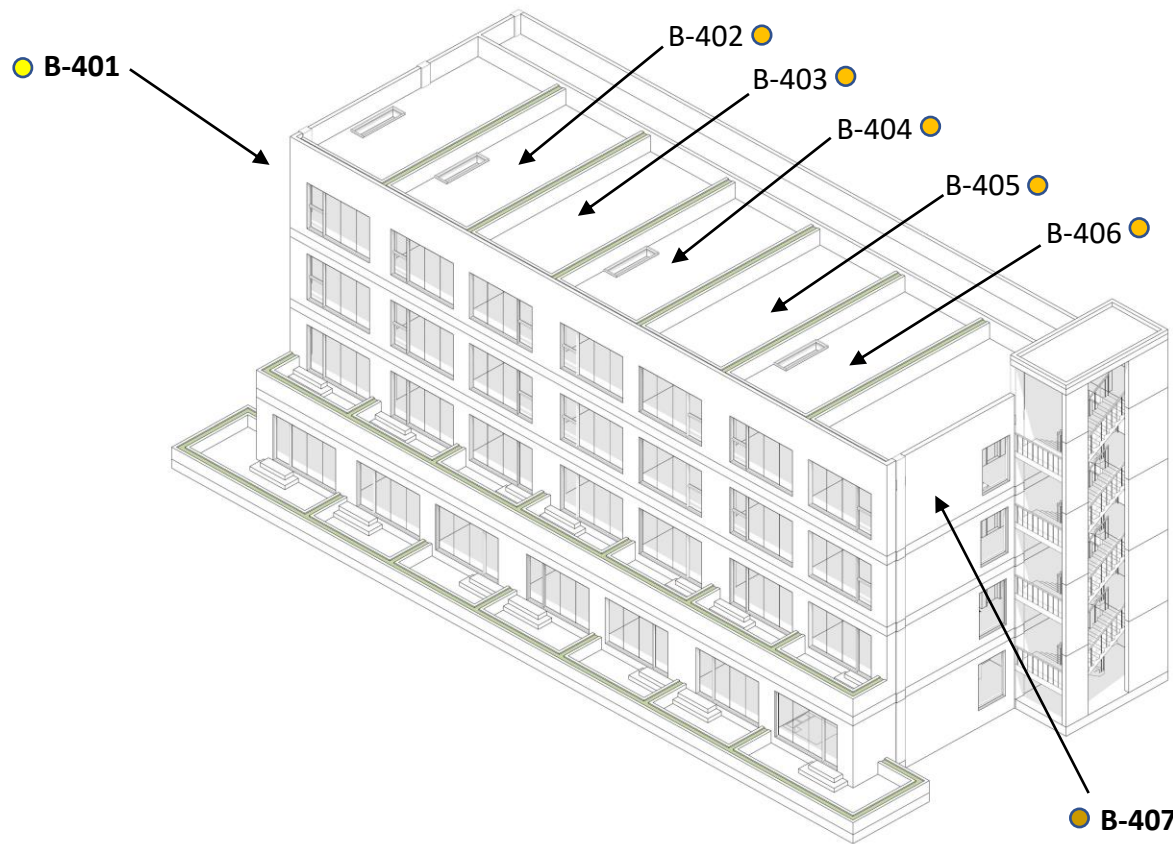

TORRE **B** PISO 4

PISO	TORRE B	m2	m2 extra	PRECIO
4	B-401	56.34	56.34	129,900
	B-402	55.34	55.34	129,900
	B-403	55.34	55.34	129,900
	B-404	55.34	55.34	129,900
	B-405	55.34	55.34	129,900
	B-406	55.34	55.34	129,900
	B-407	56.34	56.34	129,900

SINGLE **1**
residences

SINGLE
residences **1**